

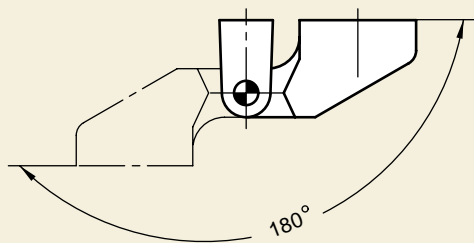

Schwenkbereich

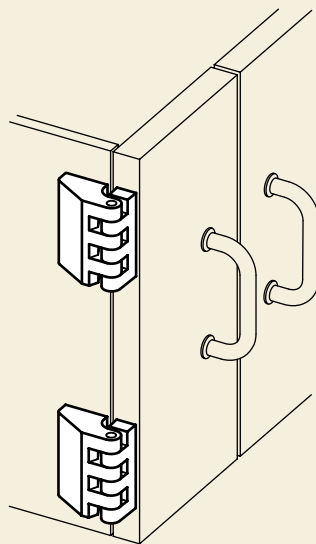

Anwendungsbeispiel



2.5